

Part No. : **S12EB7C-B**



Features :

- Highest Flux Blue
- High reliability and Very long operating life (up to 100K hours)
- Low voltage DC operated
- More Energy Efficient than Incandescent and most Halogen lamps
- NO UV
- Superior ESD protection

Typical Applications :

- Reading lights(car,bus,aircraft)
- Portable(flashlight,bicycle)
- Automotive Exterior(Stop-Tail-Turn, CHMSL,Mirror Side Repeat)
- Decorative

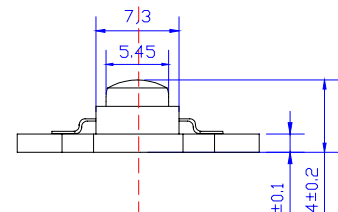
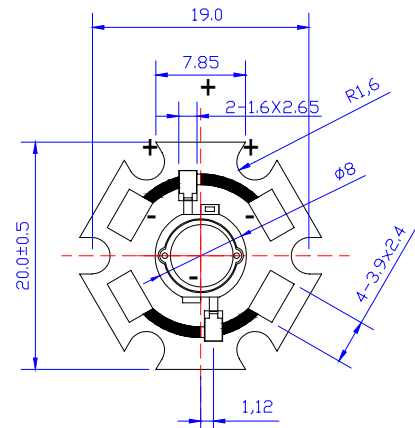

Unit: mm

NOTE:

- All dimensions are millimetres.
- Tolerance is $\pm 0.1\text{mm}$ unless o

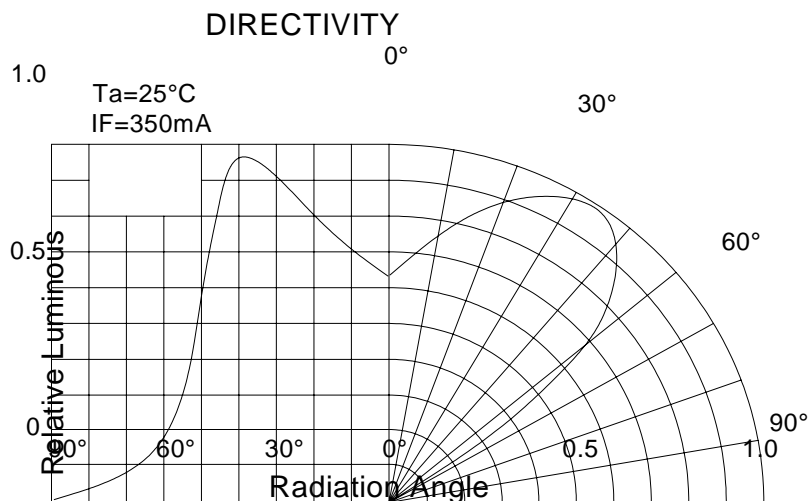

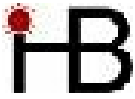

Part No. : **S12EB7C-B**

Absolute maximum ratings (Ta = 25)

Parameter	Symbol	Test Condition	Value		Unit
			Min.	Max.	
DC Forward Current	IF	----	----	350	mA
Peak Pulse Current	Ipeak	Duty=0.1mS , 1kHz	----	500	mA
Power Dissipation	Pd	----	----	1	W
LED Junction Temperature	Tj	----		120	
Operating Temperature	Topr	----	-25	+100	
Storage Temperature	Tstr	----	-40	+120	
ESD Sensitivity	---	HBM	8000	---	V
Soldering Temperature	---	-----	260 for 5 Seconds max		

Electrical and optical characteristics (Ta = 25)

Parameter	Symbol	Test Condition	Value			Unit
			Min.	Typ.	Max.	
Forward Voltage	VF	IF = 350mA	----	3.5	4.0	V
Luminous Flux	v		10	---	20	lm
Viewing Angle	2 1/2		----	90	----	Deg.
Dominant Wavelength	d		465	----	470	nm

Luminous Flux Bins (Ta = 25)

Unit:lm

Bin	C	D
Min	10	15
Max	15	20